

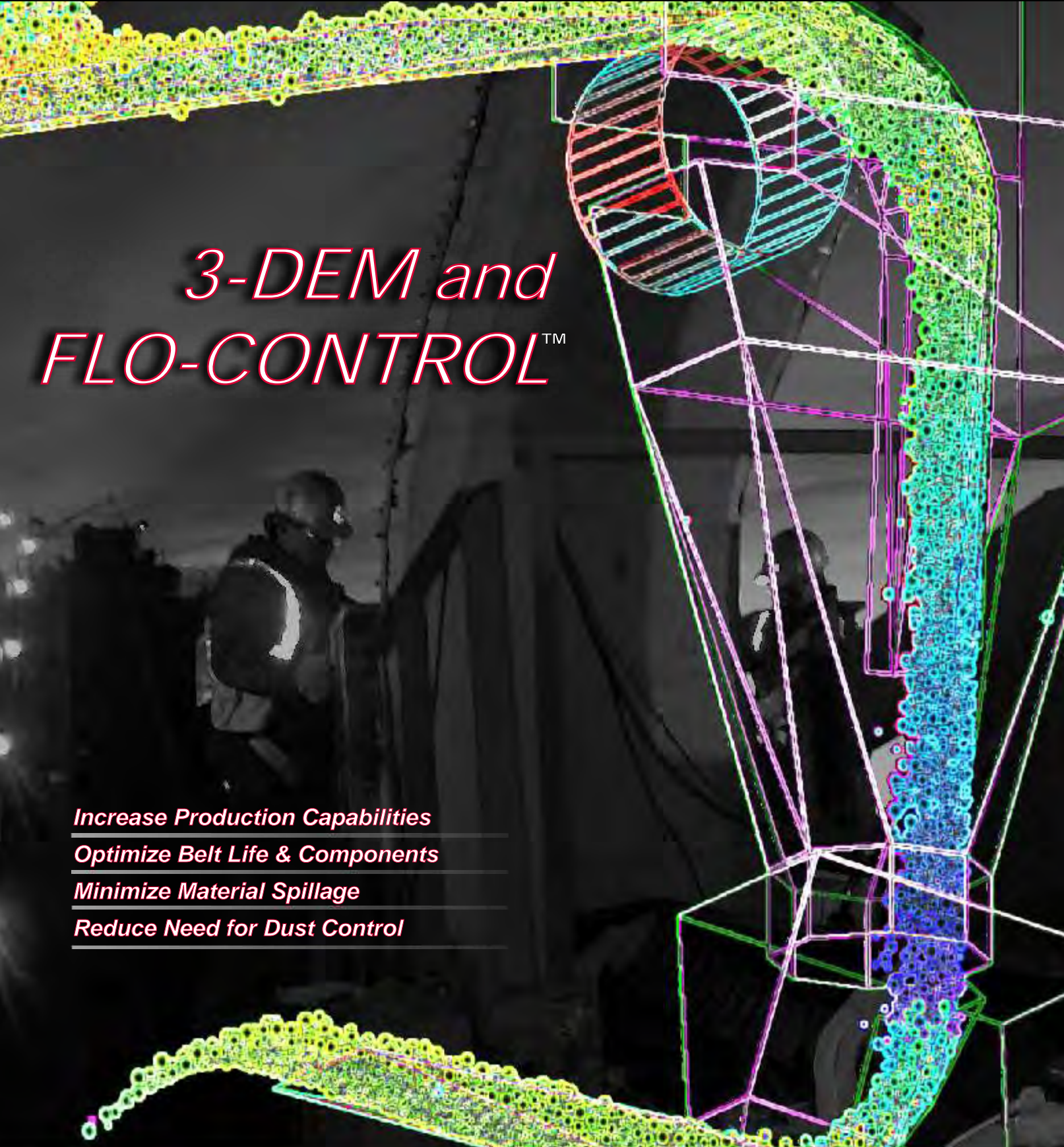

**Transfer Point Design,
Fabrication & Installation
for Improved Flo-Control™**

3-DEM and FLO-CONTROL™

- Increase Production Capabilities*
- Optimize Belt Life & Components*
- Minimize Material Spillage*
- Reduce Need for Dust Control*



3-DEM TRANSFER POINT DESIGN

Transfer point design, fabrication and installations utilizing ASGCO's 3-DEM chute analysis program (Discrete Element Methods) is a revolutionary way to handle granular and particulate material by streamlining the process from the point where material leaves the head pulley until it is deposited onto the receiving conveyor for a more deliberate control of the material as it flows from one conveyor to another. The performance of transfer chutes is an essential part to the productivity of the conveyor belt systems in the bulk solids industry.

These techniques are easily applied to both existing and new installations, resulting in significant cost improvements and system efficiencies. Combined with our conveyor and material handling knowledge, engineering capabilities and complete turn-key installation services, we are able to make transfer point problems a thing of the past.

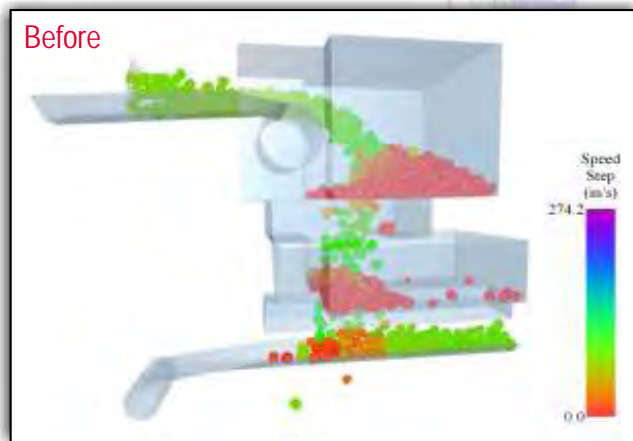

Notice the problem of all the stopped (red) particles that have created a chute-plugging problem at this transfer point.

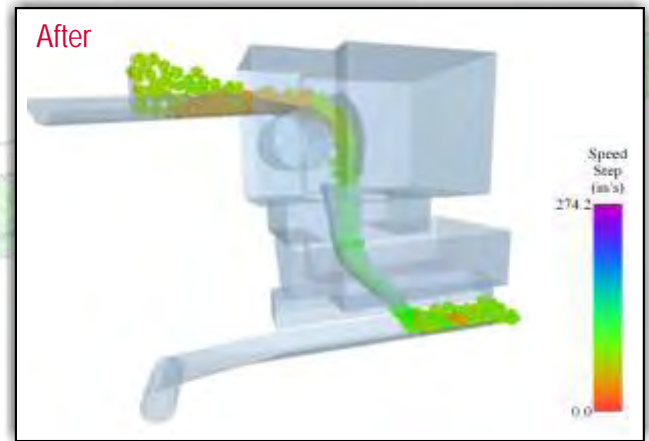

After the successful re-design using 3-DEM Chute Design program we were able to eliminate the plugging problem and have a smooth controlled flow throughout the transfer point.

The initial chute study produces a 3-D wireframe drawing of the existing chute and a 3-DEM flow simulation is run. Necessary design changes are made to optimize the flow and reduce dusting, spillage and belt wear. We then run a new 3-DEM flow simulation showing material flow and chute characteristics of the improved design. The key to a properly designed chute is steady, even and undisturbed material velocities, plus centering the material through the chutes and onto the receiving belts. Providing a uniform centered flow rate will greatly increase transfer point efficiencies, reduce belt wear, reduce back spillage and reduce material to chute impact wear and noise.

There are ten steps that need to be completed to have a trouble-free transfer point.

1. Take current drawings of existing transfer and render them accurately in 3-D CAD and fill out Data Sheet.
2. Identify chute geometry restriction and manufacturing limitations.
3. Identify customer project goals (i.e. flow restrictions, dust emissions, optimize chute and belt life).
4. Identify material properties and develop representative particle description.
5. Make design changes to chute geometry.
6. Simulate performance using 3-DEM™ Chute Design software.
7. Evaluate simulation results and choose the best design that meets the project goals.
8. Detail the new design for manufacturing.
9. Manufacture the new transfer point including other conveyor components.
10. Installation of the new transfer chute and other conveyor components (i.e. belt cleaners, skirting systems and load zone beds or rollers).

FLO-CONTROL™ (HOOD & SPOON)

The new chute can incorporate a new hood insert or a complete remodeling of the entire top and bottom of the transfer point. The head chute which will direct the material down through a lower Spoon section that will direct the flow in the direction of belt travel and centered on the belt.

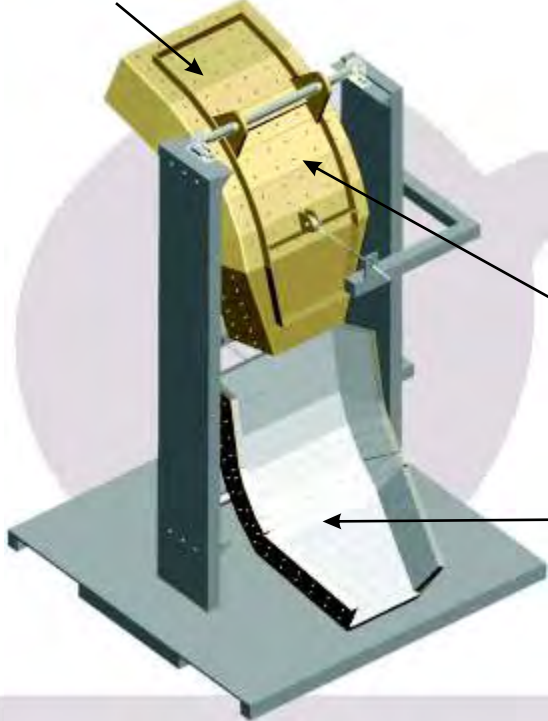

Adjustable material deflector (hood) lined with impact resistant ceramic liners are easily maintained to direct and concentrate the material flow to the center of the chute.

The adjustable impact resistant ceramic lined "Spoon" bottom chute ensures that the material is "soft-loaded" at approximately the same speed as the receiving conveyor, is also properly center loaded on the conveyor, as well as designed to eliminate any flow restrictions that would cause the potential for buildup.



- The objectives and benefits of using this type of design program are:
- Increase Production Capabilities - by helping to eliminate spillage, chute plugging, conveyor belt wear, dust control and noise.
 - Optimize Life on Conveyor Belt and Components - by minimizing impact and top cover wear by using a soft or curved chute loading design.
 - Minimize Material Spillage - in the design by center loading the material, load the material at a uniform rate and optimize the material flow in direction of travel after the belt is fully troughed.
 - Reduce the Need for Dust Control and Suppression - by minimizing the dust through loading the material at a uniform rate through a curved soft loading design, maintaining skirting, internal wear liners and dust curtains staggered throughout.



FLO-CONTROL DESIGN CHECKLIST

By: _____ Date: _____
 Company Name: _____ Contact Name: _____
 Project Name: _____ Contact E-mail: _____
 Conveyor Numbers: _____ Contact Phone: _____

| PRODUCT | |
|-----------------------|------------------------------------|
| Product being handled | Maximum continuous flow rate (TPH) |
| Capacity flow rate | Maximum surge rate (TPH) |

| TRANSFER | | |
|---------------------------------------|---------------------------------------|------------|
| Type of Transfer | Transfer Angle | |
| Head Pulley Setback from Impact Point | | |
| Minimum/Maximum Friction Angle | Angle of Repose | |
| Average Friction Angle | Maximum Lump Size | |
| Distance of Fall | Tail Pulley Setback from Impact Point | |
| Maximum Lump Size | Average Lump Size | % of Fines |

| FEED CONVEYOR | |
|--|------------------------|
| Head Pulley Diameter W/Lagging | Head Pulley Face Width |
| Belt Speed | Snub Pulley Diameter |
| Belt Width | Snub Pulley Face Width |
| Belt Specification | Angle of Incline |
| Centerline of Head Pulley to Top of Concrete | |
| Idler Manufacturer & Part # | |

| RECEIVING CONVEYOR | |
|----------------------------|------------------------|
| Tail Pulley Diameter | Tail Pulley Face Width |
| Idler Manufacturer & Part# | Length of Load Zone |
| Belt Specification | Idler Diameter |
| Belt Speed | Transition Length |
| Belt Width | |

| CUSTOMER REQUIREMENTS AND GOALS |
|---------------------------------|
| Customers Goals: |
| |
| |
| |
| |
| |
| |

Please provide accurate AutoCAD Drawing showing all Conveyor-to-Conveyor/Transfer Point Dimensions.